

The Turbine

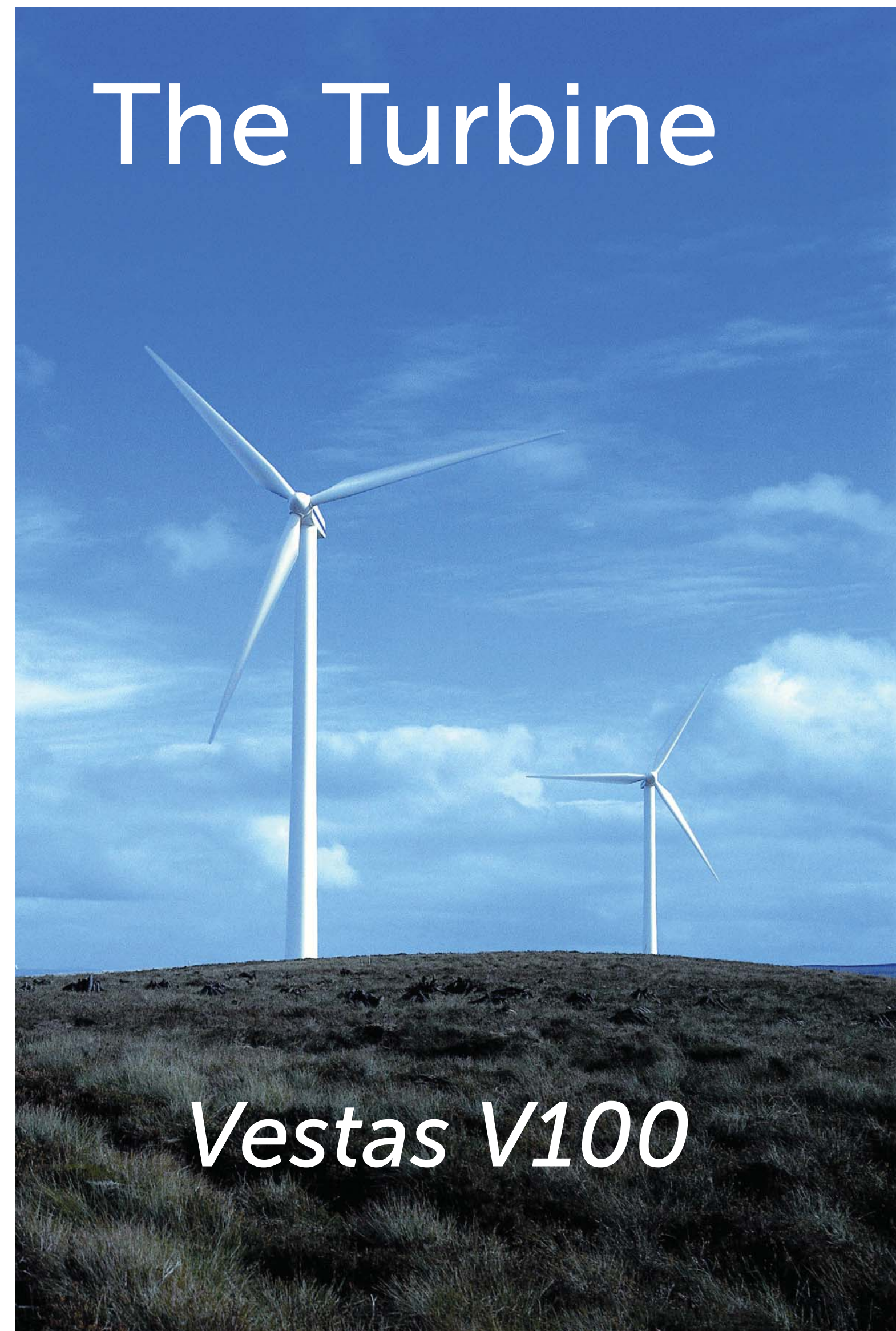

This wind energy project uses the Vestas V100 wind turbine. Vestas, a Danish company, is a long time pioneer in wind energy. Its new V100 model represents cutting edge design and technology, built on extensive testing and experience gained from the 9700+ 2MW class turbines installed worldwide



The Nacelle

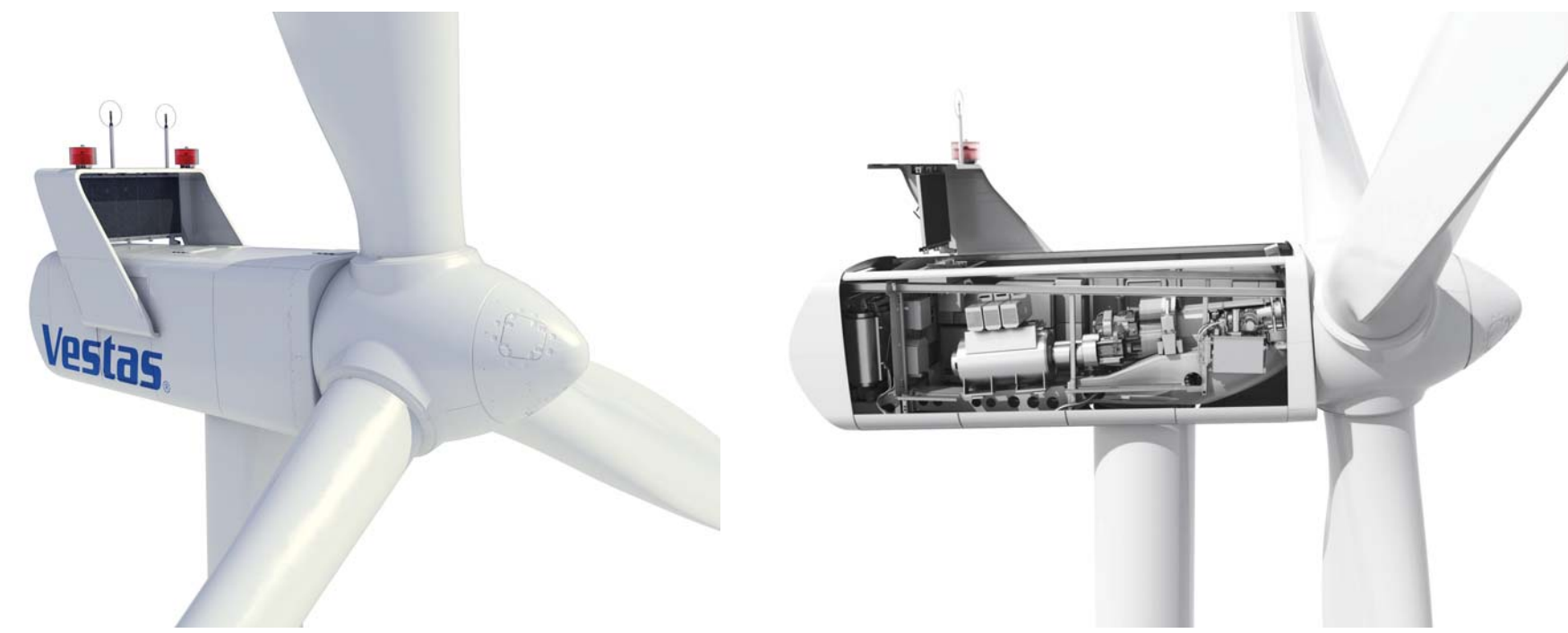

The housing that contains all of the generating components of the turbine. Inside you will find the generator, gearbox, drive train and brake assembly.

The Blades



The V100 blades are about 50 metres, 164 feet, long. Each of the three are made using lightweight composite materials to improve energy efficiency.

The longer the blade, the more wind it is able to capture energy from. The total swept area of the rotor is almost 2 acres.

Because they are so long, the tips of the blades can travel at very high speeds. However, the entire rotor spins at a maximum of 15rpm, which appears quite relaxed to the observer.

The Height

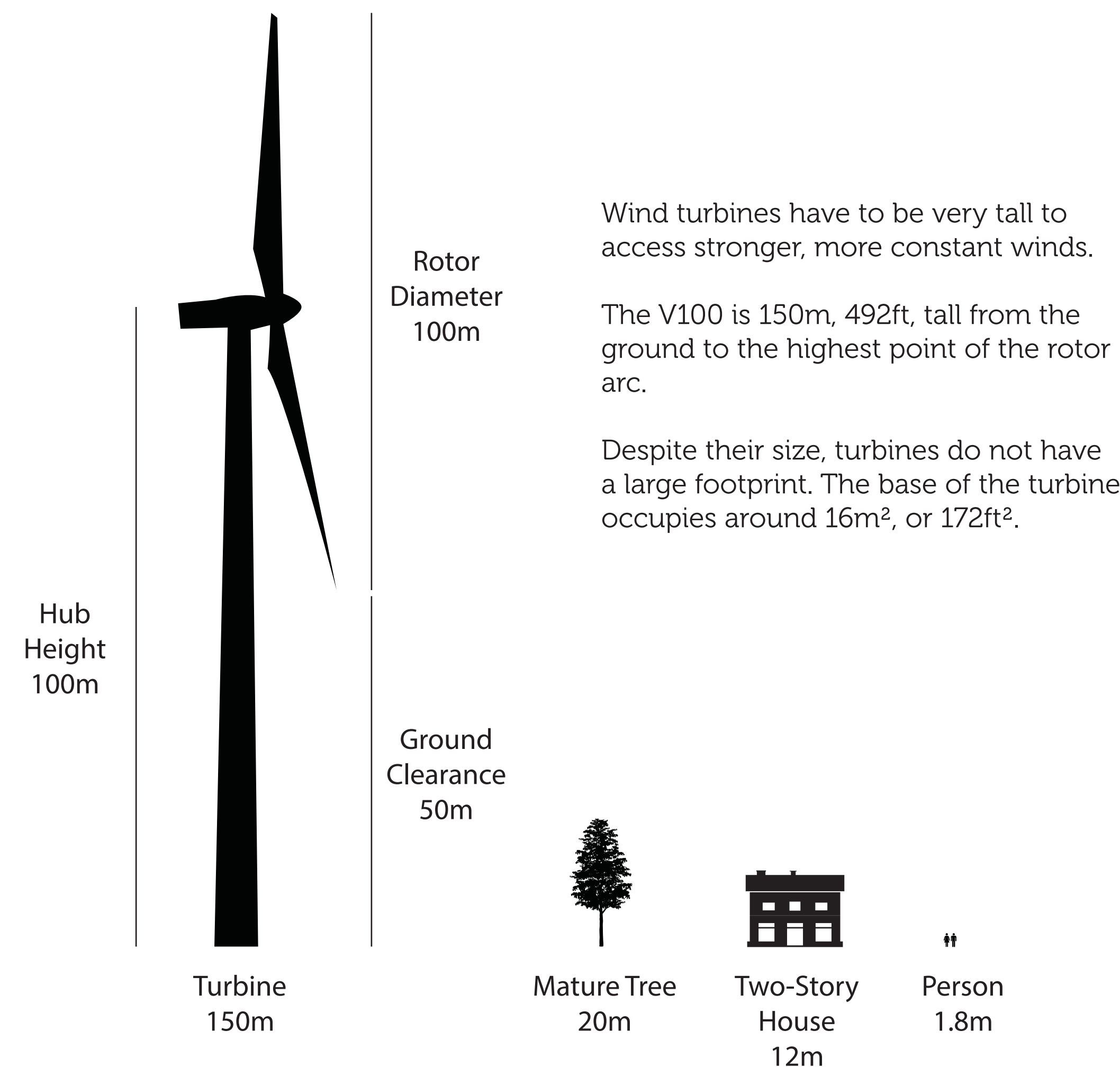

Manufacturer Specs

Generator Max Capacity: 1.99MW
 Cut-in Wind Speed: 3m/s (11km/h, 6knots)
 Cut-out Wind Speed: 20m/s (72km/h, 39knots)
 Maximum Output at: 12.5m/s (45km/h, 24knots)
 Operating Temperature Range: -20C to 40C
 (-30C with cold weather package)

Sound Power
 max: 105 dB(A)

Rotor Diameter: 100m
 Swept Area: 7850m²
 Revolution Speed: 8.8-14.9rpm
 Brake System: Blade Pitch Control + Hydraulic Disk Brake

Tower Height: 100m, Tubular Steel

In addition to manufacturer standard systems, the turbine will be equipped with an advanced real-time monitoring system. Sensors throughout the nacelle feed operational data to a manned control centre. Any irregularities can be identified 24/7/365 to ensure early preventative action is taken.

